



solar electricity

165 WATT

MULTI-PURPOSE MODULE

NEC 2008 Compliant



NE-165UC1

MULTI-PURPOSE 165 WATT MODULE FROM THE WORLD'S TRUSTED SOURCE FOR SOLAR.

Using breakthrough technology, made possible by nearly 50 years of proprietary research and development, Sharp's NE-165UC1 solar module incorporates an advanced surface texturing process to increase light absorption and improve efficiency. Common applications include commercial and residential grid-tied roof systems as well as ground mounted arrays. Designed to withstand rigorous operating conditions, this module offers high power output per square foot of solar array.

Multi-purpose module ideal for ground and roof mounted solar systems.

ENGINEERING EXCELLENCE

High module efficiency for an outstanding balance of size and weight to power and performance.

DURABLE

Tempered glass, EVA lamination and weatherproof backskin provide long-life and enhanced cell performance.

RELIABLE

25-year limited warranty on power output.

HIGH PERFORMANCE

This module uses an advanced surface texturing process to increase light absorption and improve efficiency.

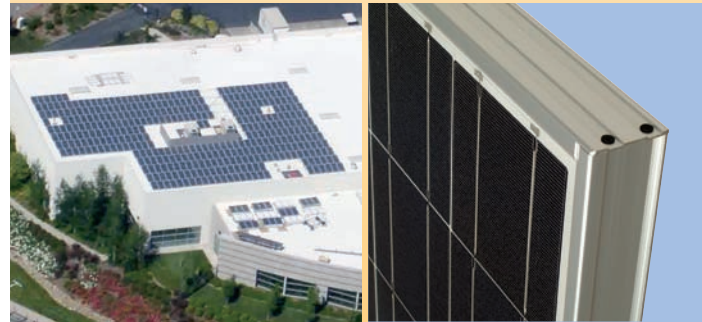

Sharp multi-purpose modules offer industry-leading performance for a variety of applications.

Improved Frame Technology

SHARP: THE NAME TO TRUST

When you choose Sharp, you get more than well-engineered products. You also get Sharp's proven reliability, outstanding customer service and the assurance of our 25-year limited warranty on power output. A global leader in solar electricity, Sharp powers more homes and businesses than any other solar manufacturer worldwide.

BECOME POWERFUL

165 WATT

NE-165UC1

NEC 2008 Compliant

Module output cables now 12 AWG with locking connectors

ELECTRICAL CHARACTERISTICS

Maximum Power (Pmax)*	165 W
Tolerance of Pmax	+10%/-5%
Type of Cell	Polycrystalline silicon
Cell Configuration	72 in series
Open Circuit Voltage (Voc)	43.1 V
Maximum Power Voltage (Vpm)	34.6 V
Short Circuit Current (Isc)	5.31 A
Maximum Power Current (Ipm)	4.77 A
Module Efficiency (%)	12.7%
Maximum System (DC) Voltage	600 V
Series Fuse Rating	10 A
NOCT	47.5°C
Temperature Coefficient (Pmax)	-0.485%/°C
Temperature Coefficient (Voc)	-0.36%/°C
Temperature Coefficient (Isc)	0.053%/°C

*Measured at (STC) Standard Test Conditions: 25°C, 1 kW/m² insolation, AM 1.5

MECHANICAL CHARACTERISTICS

Dimensions (A x B x C below)	32.5" x 62.0" x 1.8"/826 x 1575 x 46 mm
Cable Length (G)	43.3"/1100 mm
Output Interconnect Cable**	12 AWG with MC4 Locking Connector
Weight	35.3 lbs / 16.0 kg
Max Load	50 psf (2400 Pascals)

**A safety lock clip (Multi Contact part number PV-SSH4) may be required in readily accessible locations per NEC 2008 690.33 (C)

QUALIFICATIONS

UL Listed	UL 1703
Fire Rating	Class C



WARRANTY

25-year limited warranty on power output
Contact Sharp for complete warranty information

Design and specifications are subject to change without notice. Sharp is a registered trademark of Sharp Corporation. All other trademarks are property of their respective owners. Contact Sharp to obtain the latest product manuals before using any Sharp device. Cover photo: Solar installation by Pacific Power Management, Auburn CA.



SHARP®

SHARP ELECTRONICS CORPORATION
5901 Bolsa Avenue, Huntington Beach, CA 92647
1-800-SOLAR-06 • Email: sharpsolar@sharpusa.com
www.sharpusa.com/solar

IV CURVES

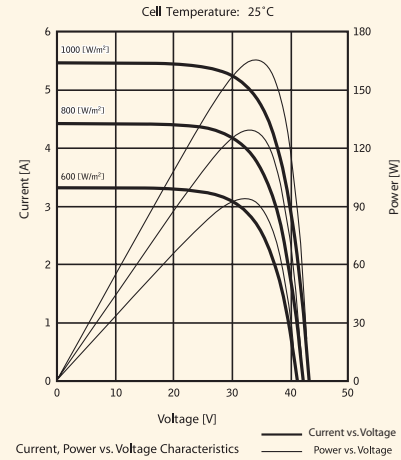

DIMENSIONS

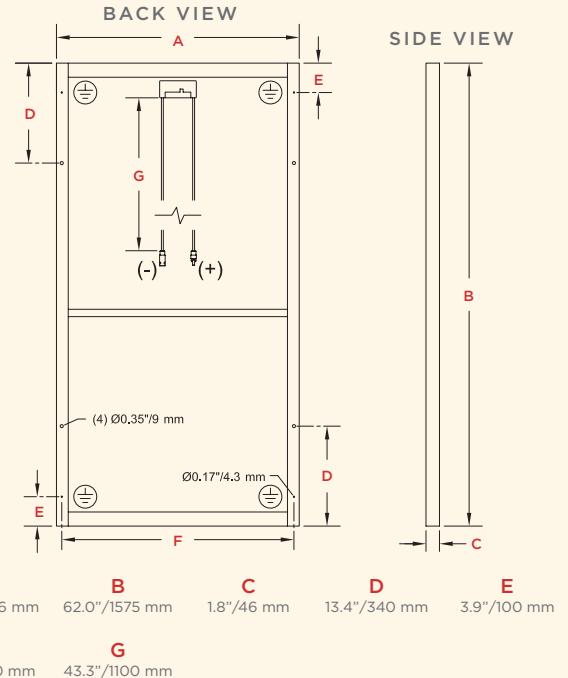

Contact Sharp for tolerance specifications